

# Whale Detangler Circuit Board

Jordan Reichhardt



# Whale Entanglements

In the last 5 years there have been over 160 whale entanglements off of the coast of California.

Many entangled whales may not die immediately but suffer injuries that impact their health, and ability to feed, or lead to infections and long-term consequences

Credit:

<https://www.fisheries.noaa.gov/>

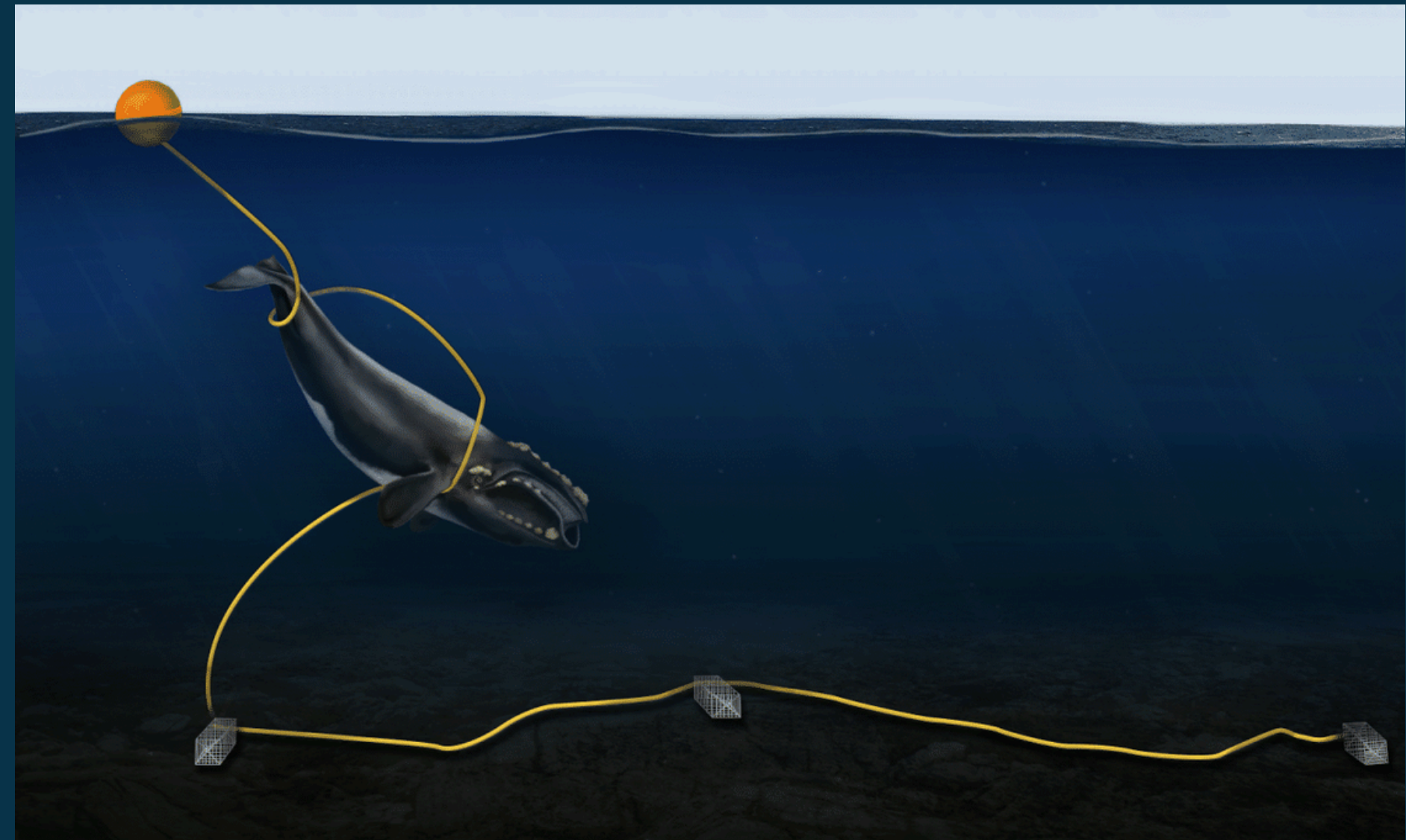

<https://us.whales.org/deep-dive-right-whale-entanglements/>



## Entanglement Ramifications

Humpback whale entangled with two commercial Dungeness crab sets; line deeply embedded in the back of the whale.

## Crab Pot Components

- Marker Bouy
- Bouy line
- Weight
- Crab pot - some operations have multiple strung together

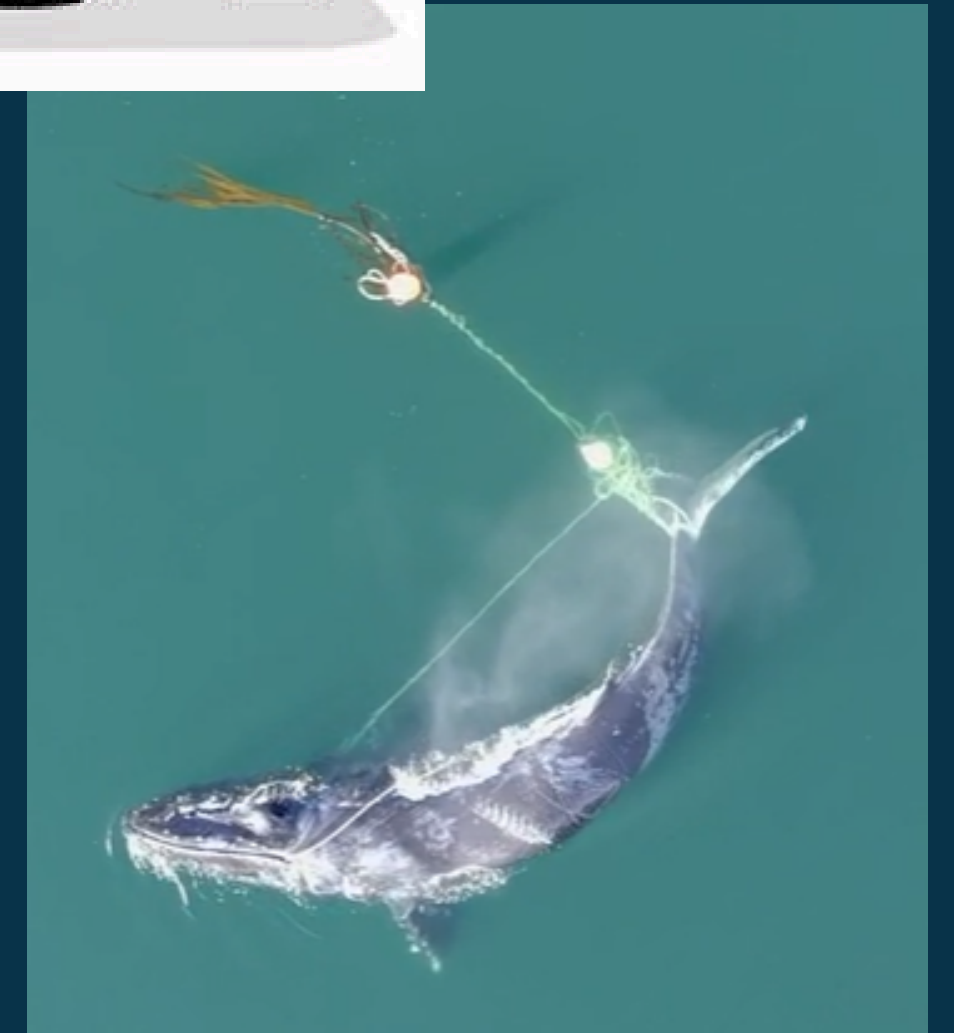
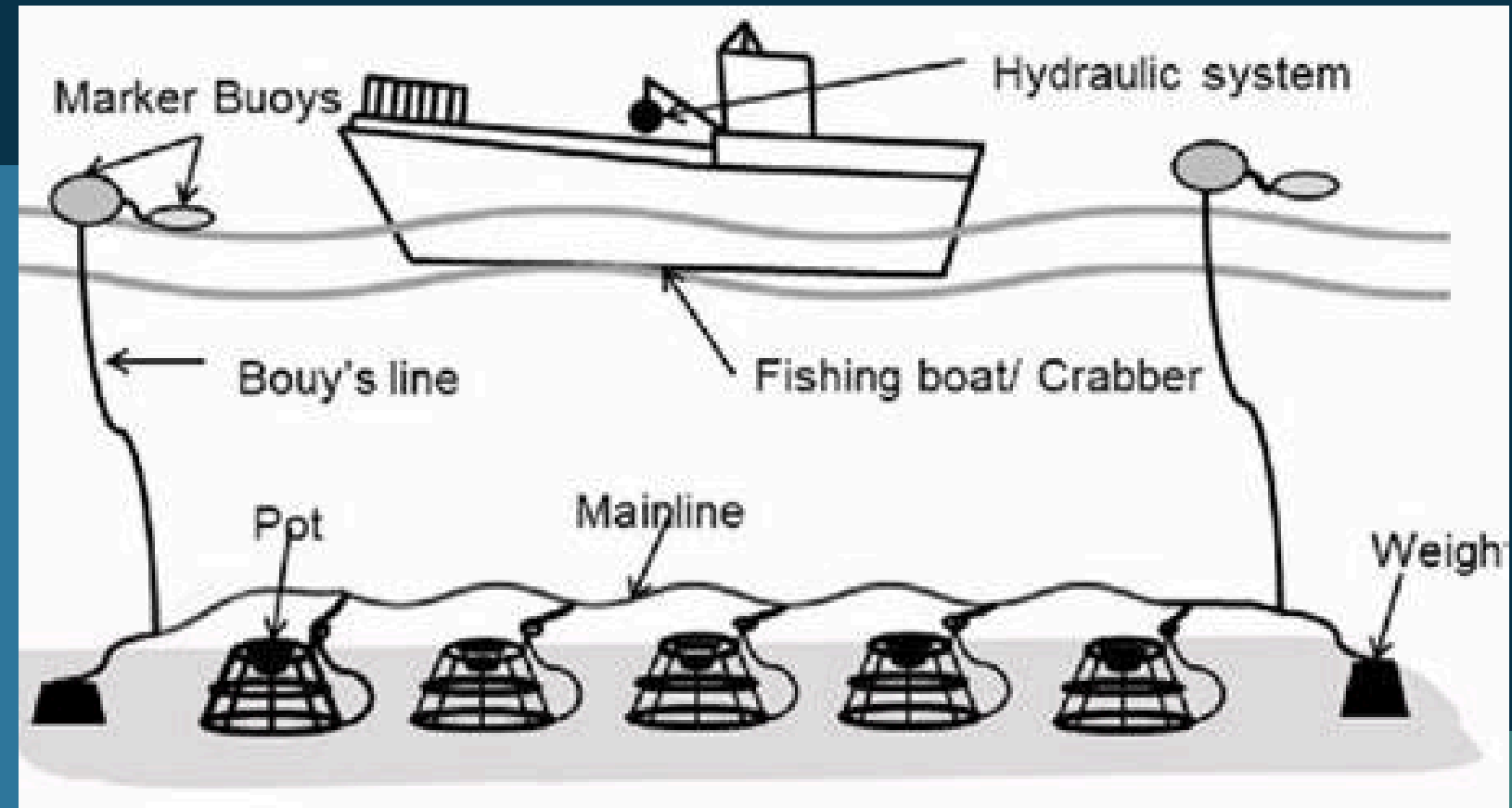

## Solution

- Whale detangler: a small electronic device that sits at the base of a crab pot between the line and pot.
- When a whale is detected the circuit activates a tiny explosion which cuts the line from the pot.

# Printed Circuit Board Schematic

Arduino Pro Mini (B1)  
Microcontroller

LTC3525-3.3 (U1) Boost Converter

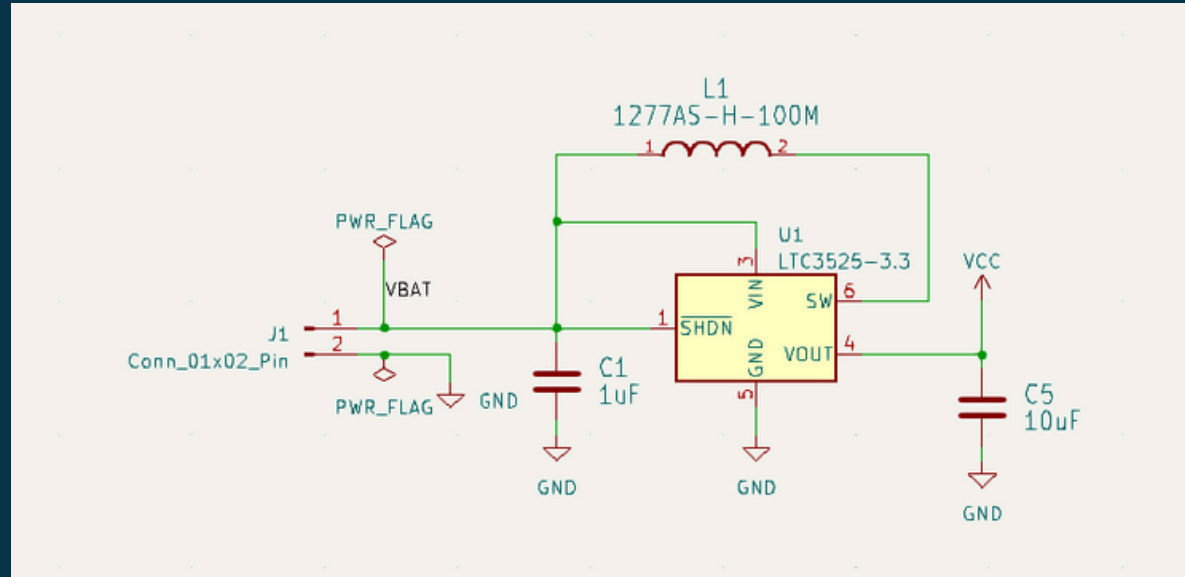

ADXL363 (U4) Accelerometer

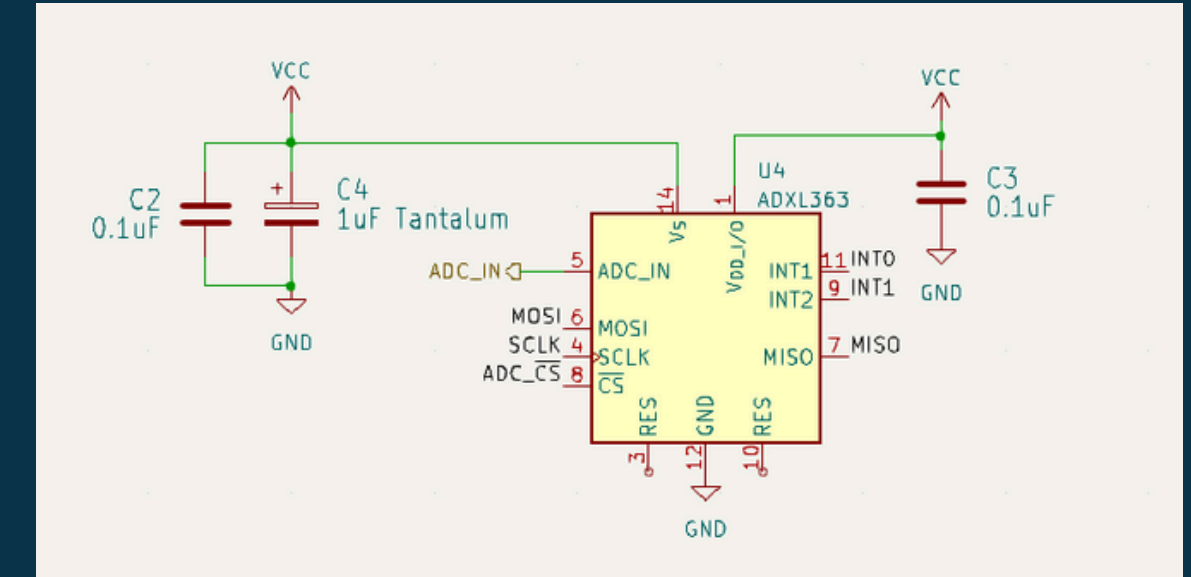

BF350 (Pressure Gauge) Setup

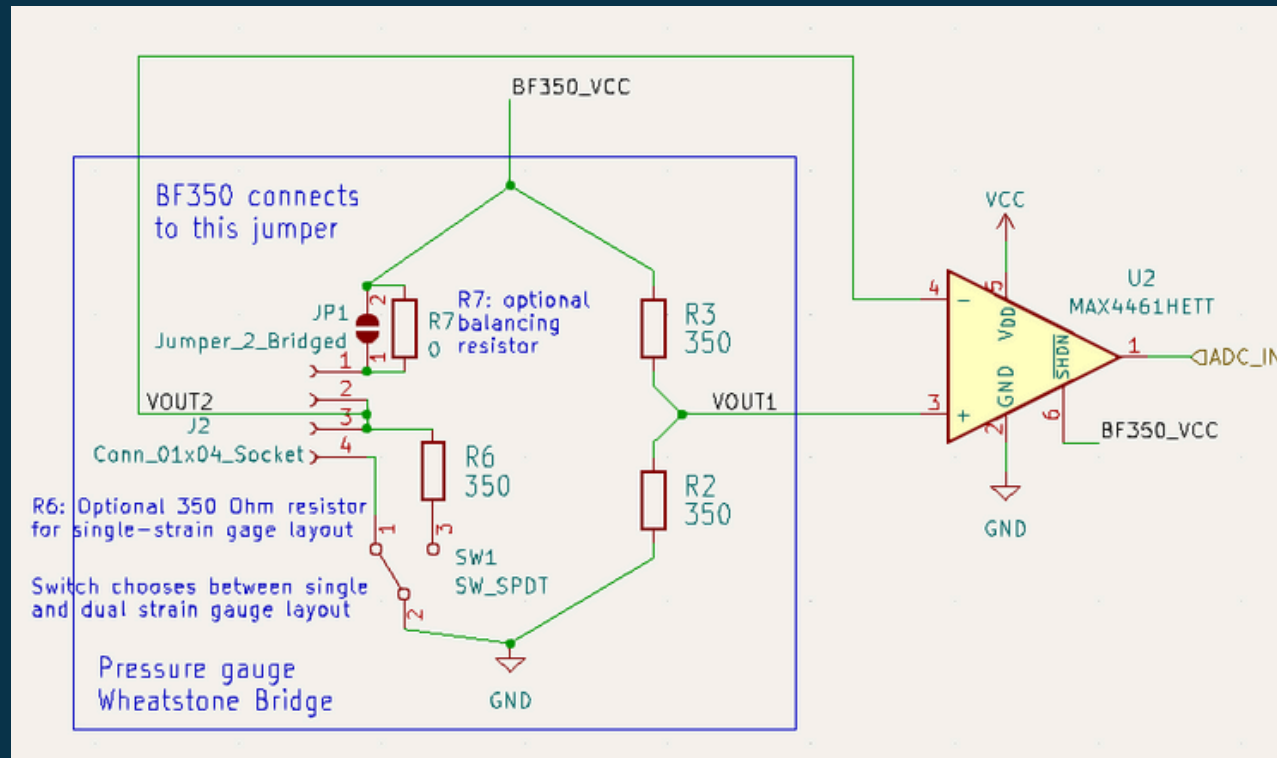

TPS61096A (U5) Power Management IC

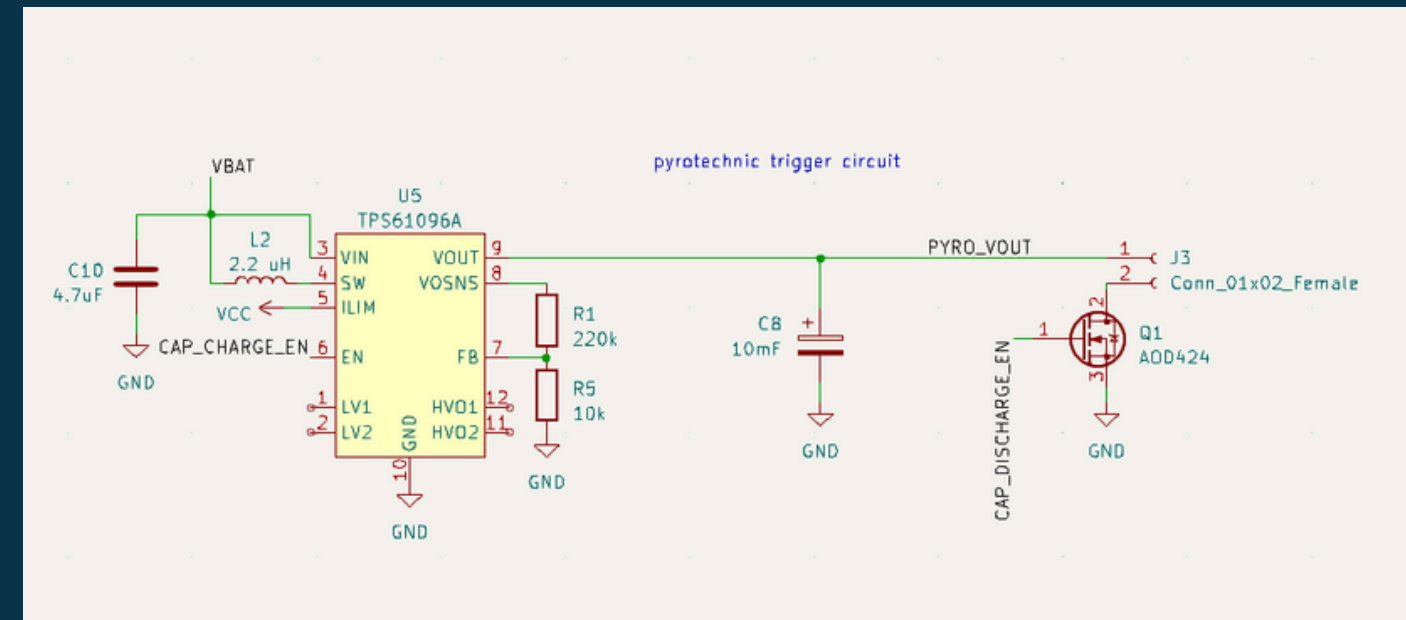

EEPROM (U3)

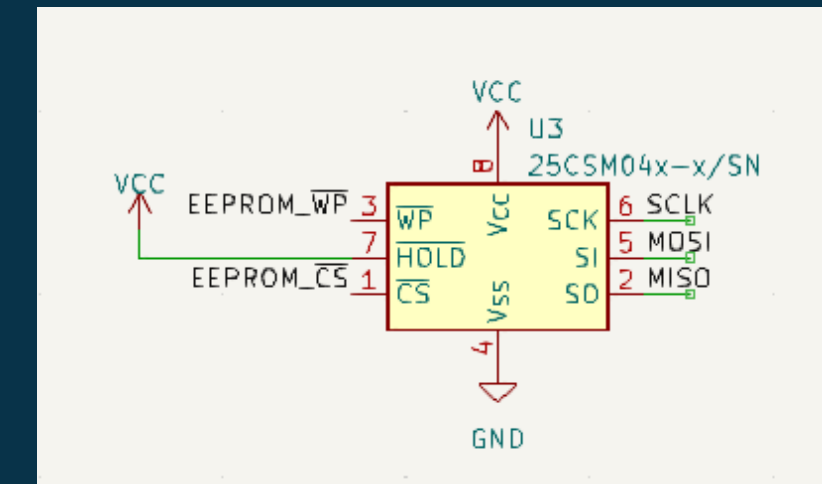

# Arduino Pro Mini (B1) Microcontroller

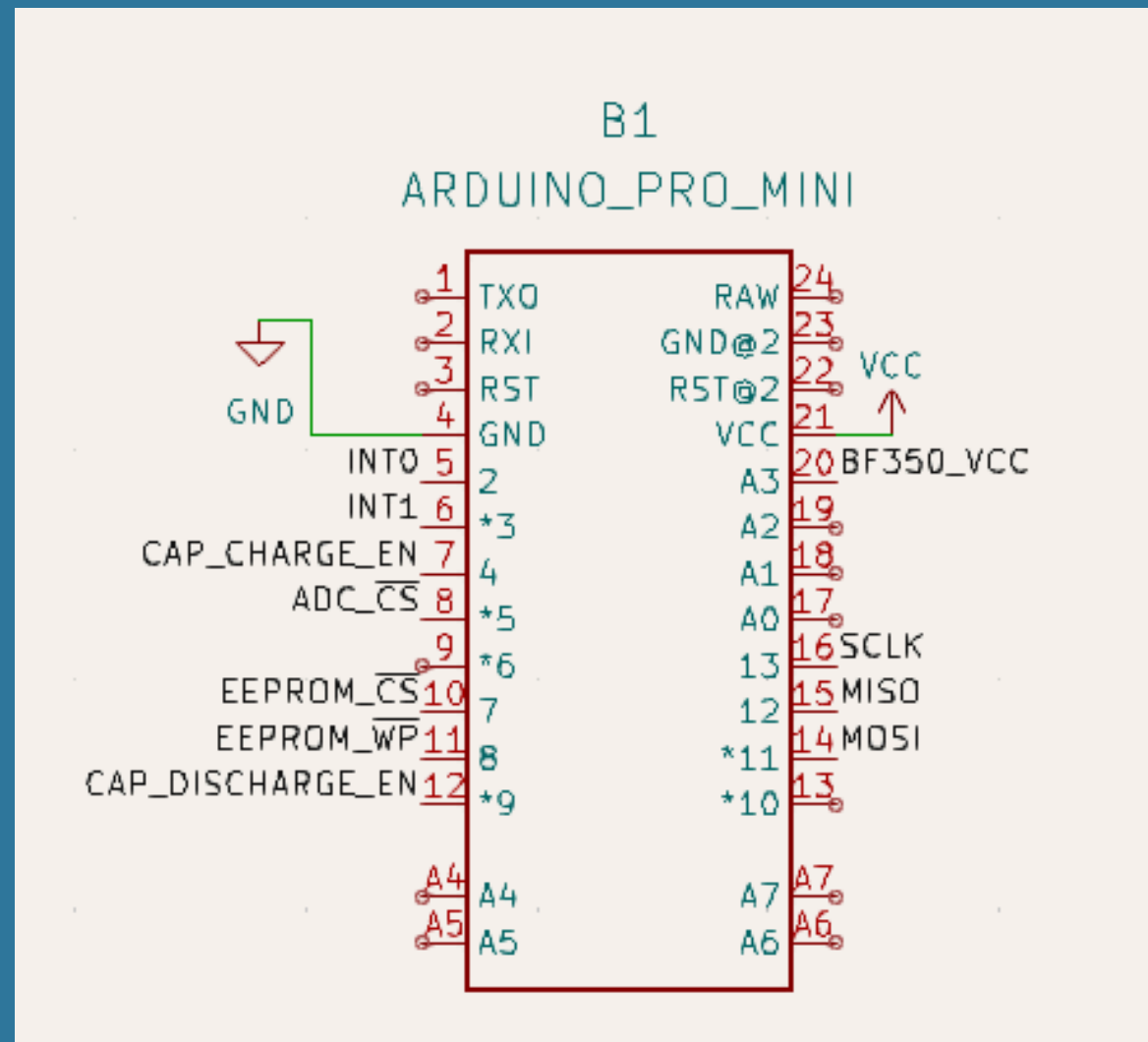

## Purpose:

- The Arduino Pro Mini acts as the primary control unit.
- It processes input signals, executes programmed instructions, and sends outputs to connected modules.

## Connections:

- Multiple GPIO pins and analog pins are connected to other sensors and modules.
- It includes connections to EEPROM and other components like an accelerometer.

# ADXL363 (U4) Accelerometer

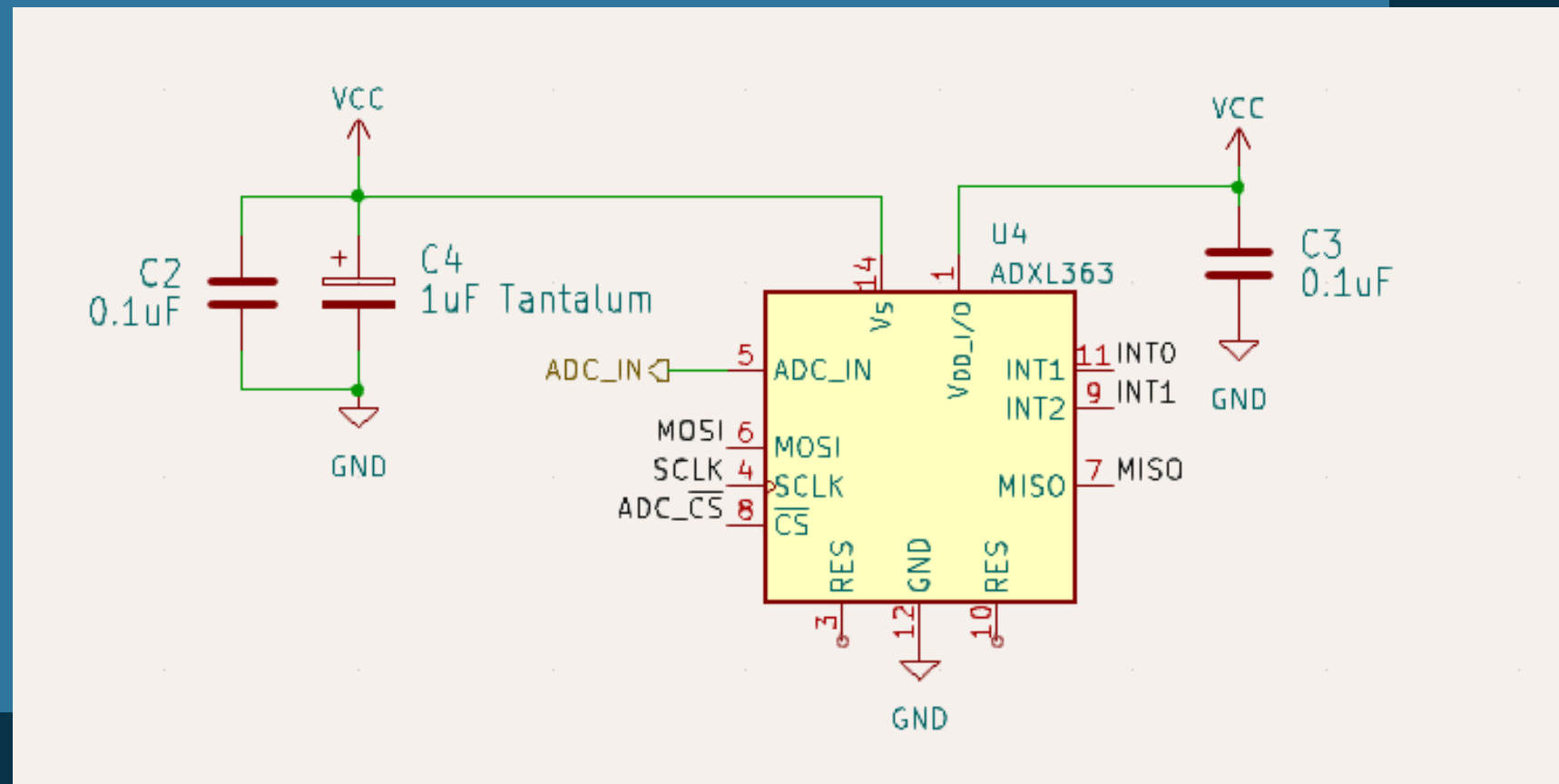

Purpose:

- Measures acceleration in three axes.

Connections:

- Communicates with the Arduino via the SPI interface.
- Capacitors C2 and C3: These stabilize the power supply to the ADXL363.

# Electrically Erasable Programmable Read-Only Memory (EEPROM -U3)

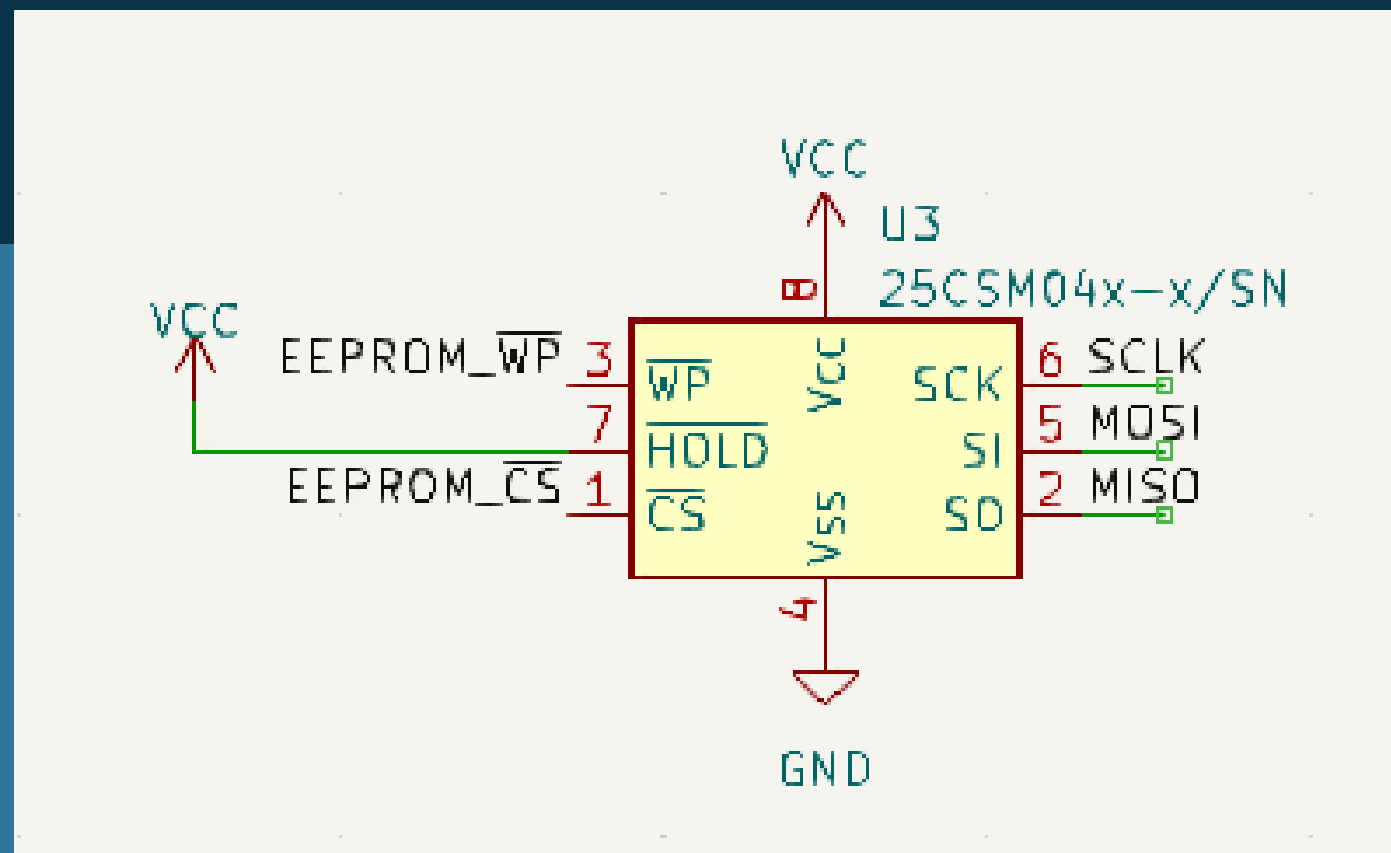

## Purpose:

- Provides non-volatile storage for the Arduino Pro Mini, allowing the system to store and retrieve data, even if the power is turned off.

## Connections:

- It communicates with the microcontroller using the SPI interface (CS, SCK, MISO, MOSI).

# Wheatstone Bridge and BF350 (Pressure Gauge) Setup

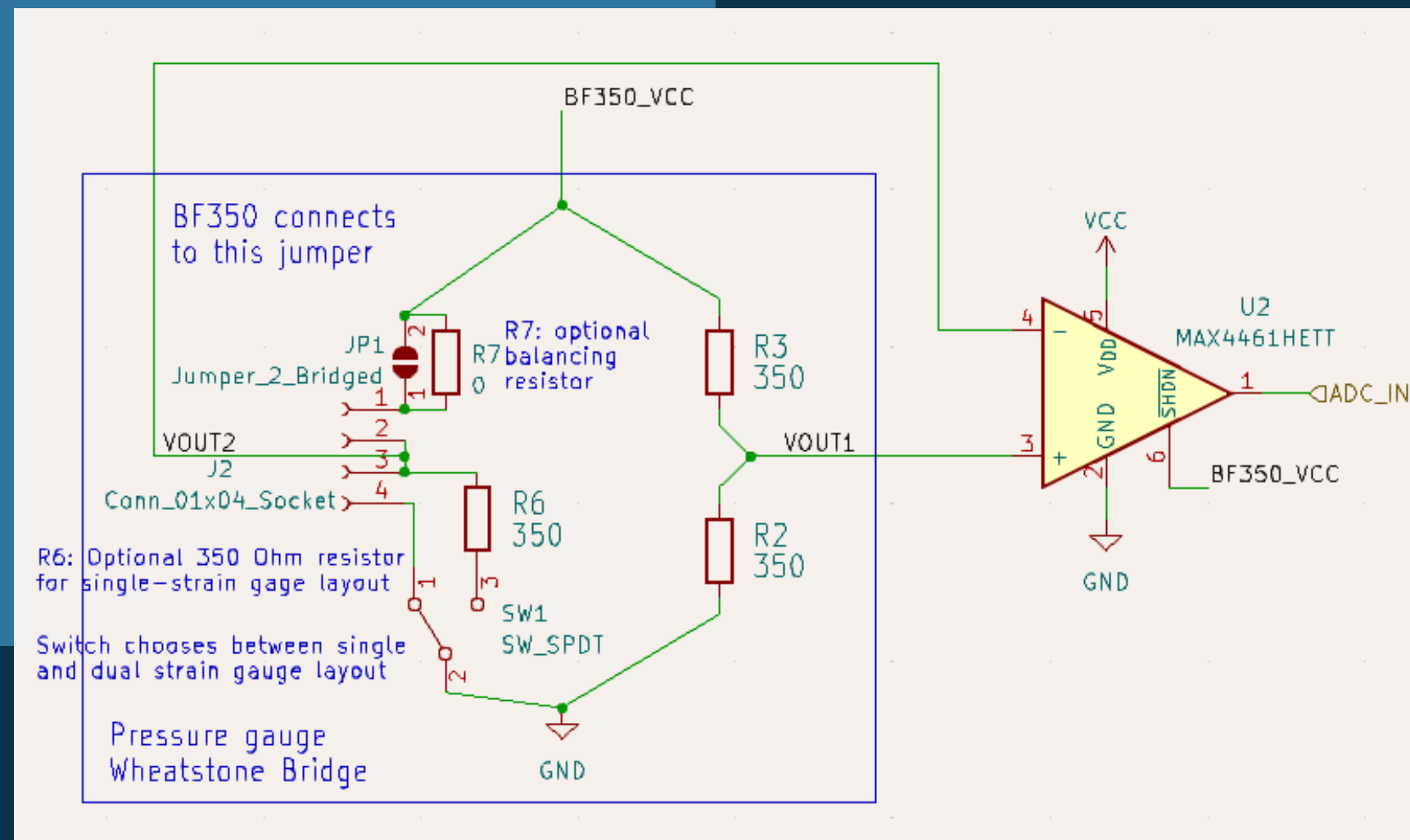

## Purpose:

- The Wheatstone Bridge and BF350 setup measures mechanical strain by detecting resistance changes in the BF350 strain gauge and converting them into a voltage difference.

## Connections:

- The BF350 is one leg of the Wheatstone Bridge along with resistors R2, R3, and R6, with R7 (balancing resistor). The resulting differential voltage is amplified by U2 (MAX4466) and sent to an ADC input for processing.

# LTC3525-3.3 (U1) Boost Converter

Purpose:

- This component is a DC-DC boost converter which takes a lower or fluctuating battery voltage and raises it to a consistent 3.3V output.

Components:

- L1 (1277AS-H-100M): An inductor that is used to store energy for the boost operation.
- C1 (1 $\mu$ F) and C5 (10 $\mu$ F): Capacitors that smooth out the input and output voltages, respectively.
- SHDN Pin: A shutdown control pin to turn the boost converter on or off.

Output Voltage:

- VOUT2 is the stable 3.3V generated for powering other parts of the circuit.

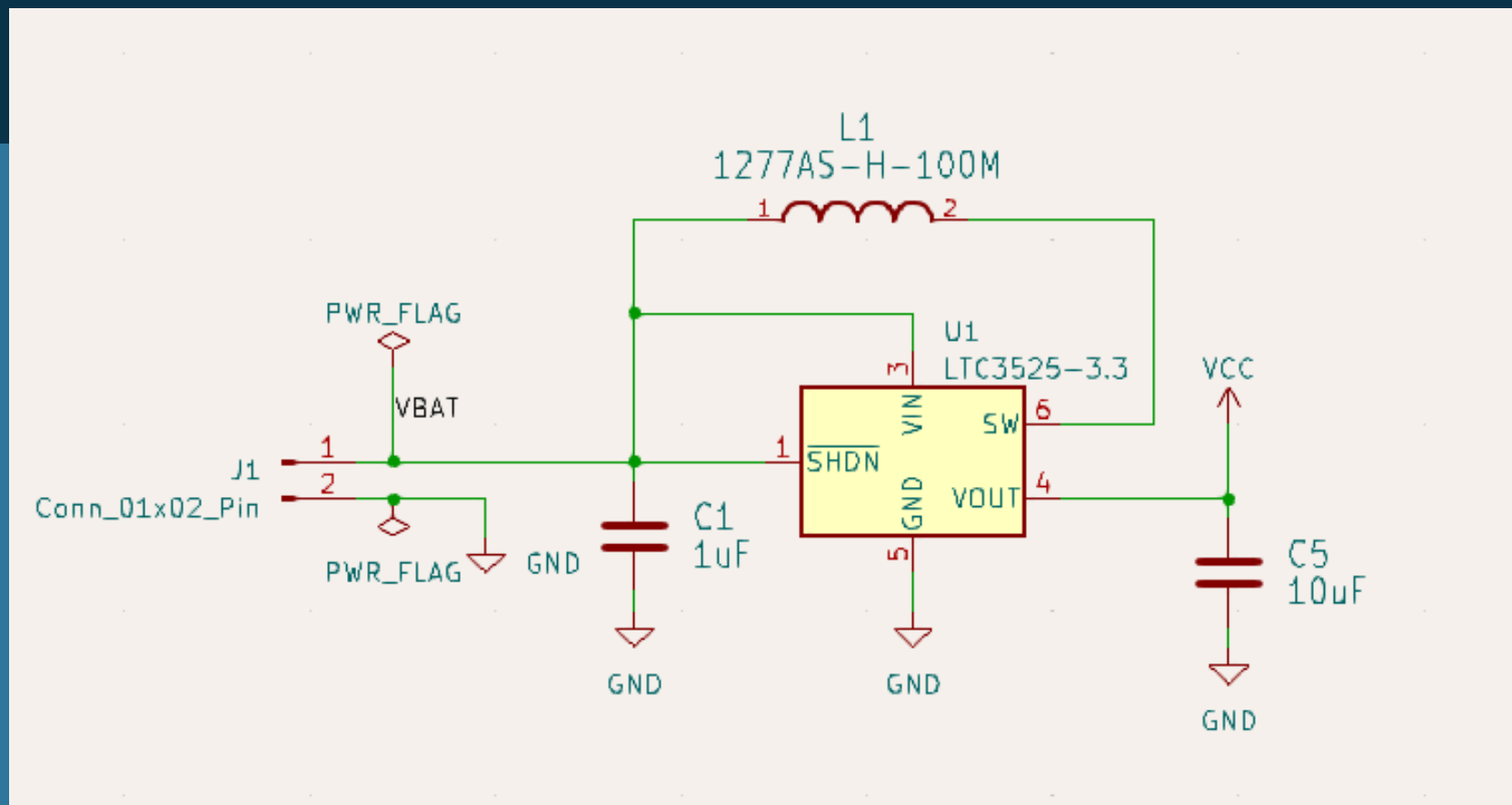

# TPS61096A (U5) Power Management IC and Pyrotechnic Trigger Circuit

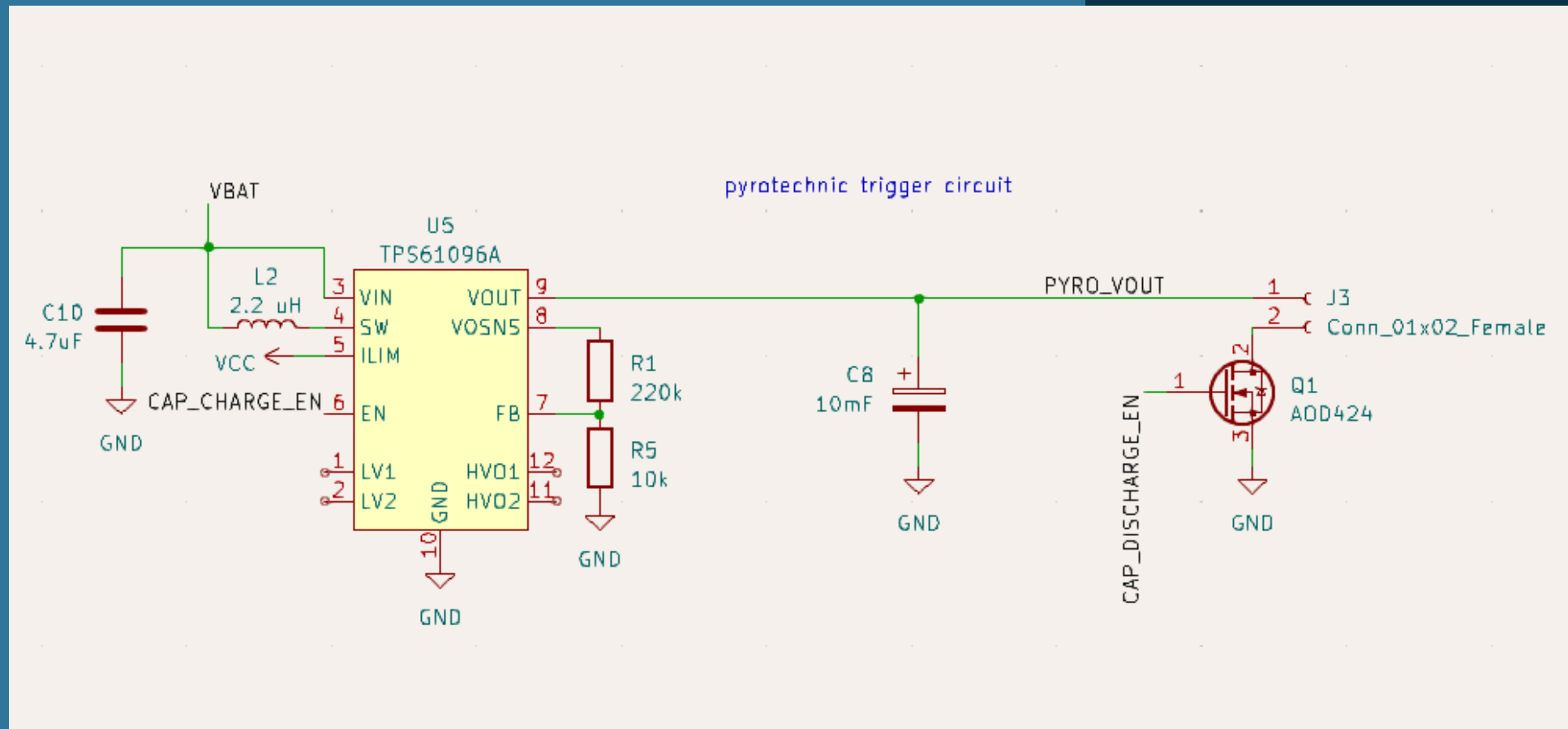

## TPS61096A:

- Purpose: Provides a regulated output voltage (likely to power a higher-voltage circuit or charge a capacitor).
- L2 (2.2µH): Works in conjunction with U5 to regulate the output voltage.
- Capacitors C10, C8: Smooth the input and output voltages for the power regulation circuit.

## Pyrotechnic Trigger:

- Purpose: Manages the controlled triggering of a pyrotechnic device.
- Q1 (AO4424 MOSFET): Acts as a switch to control the discharge of a capacitor into the pyrotechnic device.
- Capacitor C8 (10nF): Stores the energy to be discharged when triggered.
- Resistors R1 and R5: Configure the discharge behavior and switching threshold.



# Thanks for listening!



Contact:

Student project lead:

- Jordan Reichhardt
- [jreichha@calpoly.edu](mailto:jreichha@calpoly.edu)

Principle Investigator:

- Dr. Dridget Benson
- [bbenson@calpoly.edu](mailto:bbenson@calpoly.edu)